

TOSHIBA BiCD Digital Integrated Circuit Silicon Monolithic

TB62757FPG

Step Up Type DC/DC Converter for White LED

The TB62757FPG is a high efficient Step-Up Type DC/DC Converter specially designed for constant current driving of White LED.

This IC can drive 2 to 6 white LEDs connected series using a Li-ion battery.

This IC contains N-ch MOS-FET Transistor for Coil-Switching, and LED Current (I_F) is set with an external resistor.

This IC is especially for driving back light white LEDs in LCD of PDA, Cellular Phone, or Handy Terminal Equipment.

This device is Pb-free product.

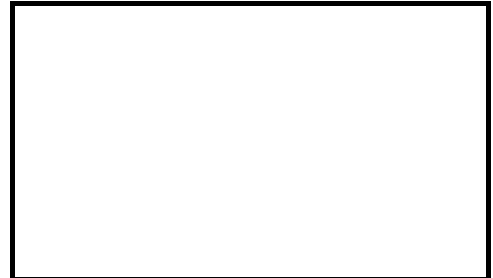

Weight: TBD g (typ.)

Features

- Can drive 2 to 6 white LEDs connected series
- Variable LED current I_F is set with a external resistor: 20 mA (typ.) @ $R_{SENS} = 16 \Omega$
- Output power: Available for 400 mW LED loading
- High efficiency: 87% @Maximum
- Output over voltage shutdown function:
Switching operation is shut downed when OVD terminal voltage is over 22 V (typ.).
- IC package: PLP-6
- Switching frequency: 1.1 MHz (typ.)

Block Diagram

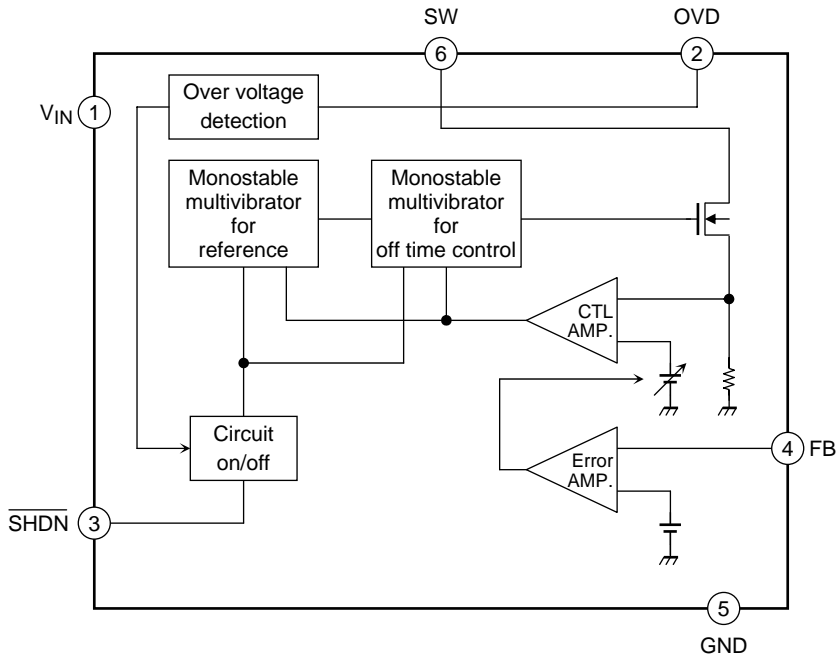

Pin Assignment (top view)

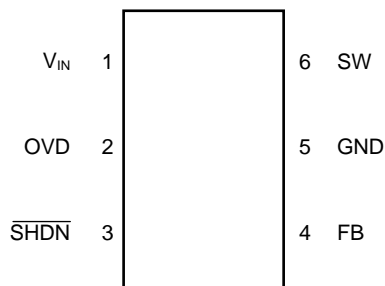

Note 1: This IC could be destroyed in some case if amounted in 180° inverse direction.
Please be careful about IC direction in mounting.

Pin Function

| Pin No. | Symbol | Function Description |
|---------|--------------------------|---|
| 1 | V _{IN} | Supply voltage input terminal. (2.8 V to 5.5 V) |
| 2 | OVD | Over voltage detection terminal. IC switching operation is disabled with detection over voltage. If the voltage returns to detection level or less, operation is enabled again. |
| 3 | $\overline{\text{SHDN}}$ | Voltage-input terminal for IC-enable. $\overline{\text{SHDN}} = \text{H} \rightarrow$ Operation Mode, $\overline{\text{SHDN}} = \text{L} \rightarrow$ Shutdown Mode (IC shutdown) Please do not open this terminal. |
| 4 | FB | LED I _F setting resistor connecting terminal. |
| 5 | GND | Ground terminal. |
| 6 | SW | Switch terminal for DC/DC converter. Nch MOSFET built-in. |

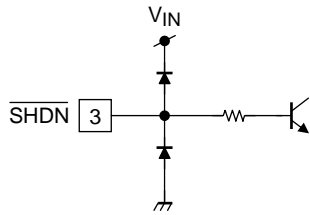
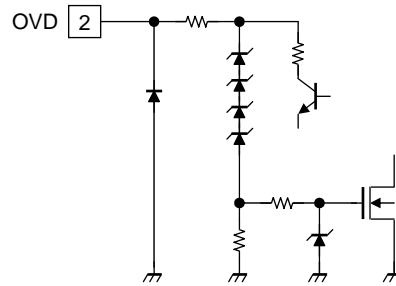
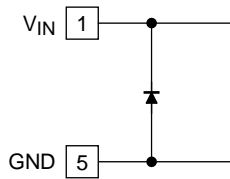
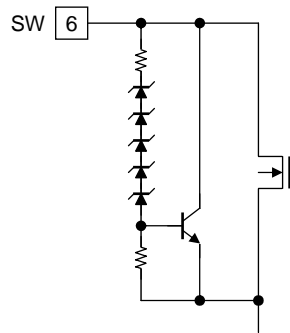
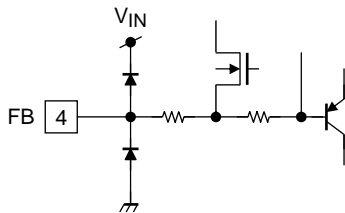
I/O Equivalent Pin Circuits**1. SHDN Terminal****2. OVD Terminal****3. V_{IN} Terminal to GND Terminal****4. SW Terminal****5. FB Terminal**

Application Note

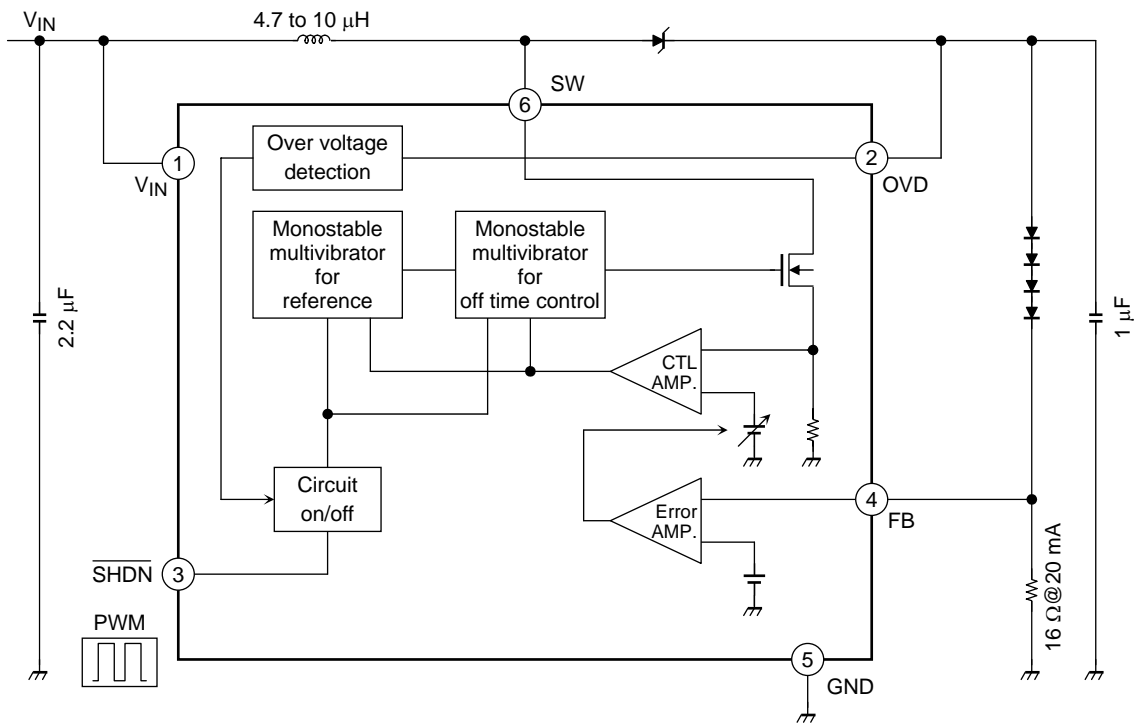

Protection in LED Opened Condition (OVD Function)

The operation with OVD terminal is available for the protection in case LED Circuit opened.
 If load of LED is detached, Nch MOS switching operation is disabled with detection of boost circuit voltage.
 (* When the voltage value recovers below the detection voltage value, operation is restarted.)

Setting of External Capacitor

In case not using PWM signal to $\overline{\text{SHDN}}$ terminal for brightness control, recommended values are $C_1 = \text{Over } 2.2 (\mu\text{F})$, $C_2 = \text{Over } 1.0 (\mu\text{F})$

In case with PWM signal to $\overline{\text{SHDN}}$ terminal for brightness control, recommended values are $C_1 = \text{Over } 4.7 (\mu\text{F})$, $C_2 = \text{Under } 0.1 (\mu\text{F})$.

The recommended capacitor values depend on the Brightness Control Method.

<Please refer the next page or later>

The capacitor value must be considered for gain enough accuracy of brightness with reduction of noise from Input current changing.

Setting of External Inductor Size

Please select the inductor size with referring this table corresponding to each number of LEDs.

| LEDs | Indictor Size | Note |
|------|-------------------|-----------------------------------|
| 2 | 4.7 μH | LED current $I_F = 20 \text{ mA}$ |
| 3 | | |
| 4 | 6.8 μH | |
| 5 | 8.1 μH | |
| 6 | 10 μH | |

LED Current I_F Setting

The resistance between the FB pin and GND, $R_{\text{SENS}} (\Omega)$ is the resistance for the setting the output current.

Depending on the resistance value, it is possible to set the average output current I_o (mA).

The average output current I_o (mA) can be approximated with the following equation:

$$I_F = (325 [\text{mV}] / R_{\text{SENS}} [\Omega])$$

The current value error is $\pm 5\%$.

Brightness Control Method

Recommended Brightness Control Circuits are 4 types.

- 1) Input PWM signal to $\overline{\text{SHDN}}$ terminal
 I_F can be adjusted with PWM signal by inputting it to $\overline{\text{SHDN}}$ terminal.

[Notice]

<<Minimum ON-time of PWM signal input>>

- Set the minimum ON-time or OFF-time 33 μs or more in inputting the PWM signal.
- Set the Duty ratio satisfying the condition above.

Ex) In case PWM Frequency is 1 kHz,
 1 kHz is 1 ms (PWM Width = 100%) and it takes 10 μs per 1%.
 To set the pulse width 33 μs or more, necessary ON-or-OFF-time is calculated below.
 33 $\mu\text{s} \div 10 \mu\text{s} = 3.3\%$ (Under the condition that 10 μs equals 1%)

Finally, the Duty Ratio can be set in range of 3.3% to 96.7%.

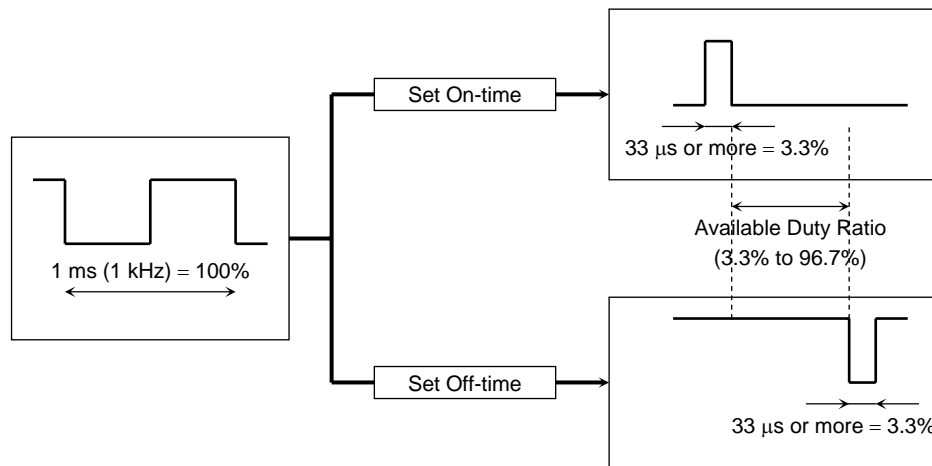

<<PWM signal frequency>>

- The recommended PWM signal frequency is from 100 Hz to 10 kHz. There is a possibility to arise the audible frequency in mounting to the board because it is within the auditory area.

<<Constant number of external capacitor>>

- To reduce the fluctuation of input current and increase the accuracy of brightness, the values that $C_1 = 4.7$ (μF) or more, $C_2 = 0.1$ (μF) or less are recommended.
- When the PWM signal is off, the time to drain C_2 of charge depends on the constant number. And so, the actual value is little different from the theoretical value.

<<PWM input signal>>

- Set the amplitude of PWM signal within the range of $\overline{\text{SHDN}}$ terminal specification.

<<Rush current in inputting>>

- In case dimming by inputting the PWM signal to the $\overline{\text{SHDN}}$ terminal, this IC turns on and off repeatedly.
 And the rush current, which provides the charge to C_2 , arises in turning on. Take care in selecting the condenser.

<<Current value in control with PWM: Ideal equation>>

$$I_F (\text{mA}) = \frac{325 [\text{mV}] \times \text{ON Duty} [\%]}{R_{\text{SENS}} [\Omega]}$$

<Reference Data>

Condition: $V_{IN} = 3.6\text{ V}$, $L = 6.8\ \mu\text{H}$, 4LEDs, $R_{SENS} = 16\ \text{m}\Omega @ I_o = 20\ \text{mA}$

(1) $C_1 = 4.7\ \mu\text{F}$, $C_2 = 0.1\ \mu\text{F}$

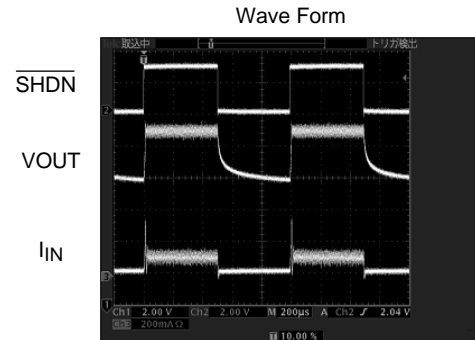
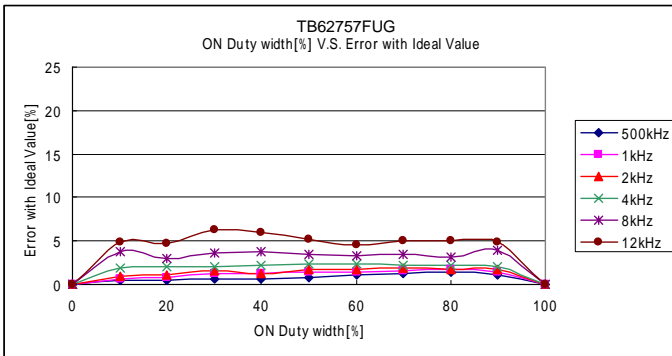

(2) $C_1 = 4.7\ \mu\text{F}$, $C_2 = 0.47\ \mu\text{F}$

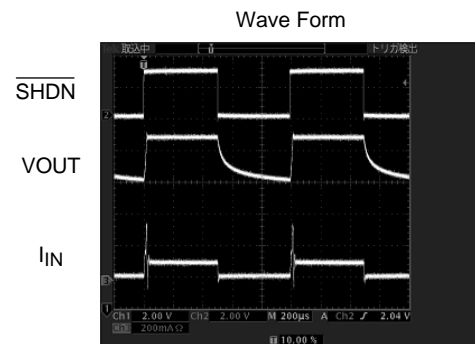
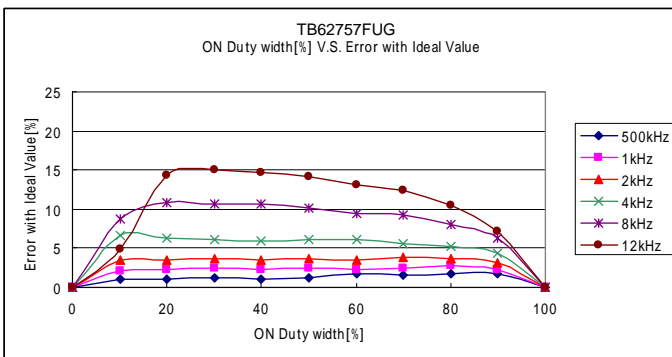

(3) $C_1 = 4.7\ \mu\text{F}$, $C_2 = 1.0\ \mu\text{F}$

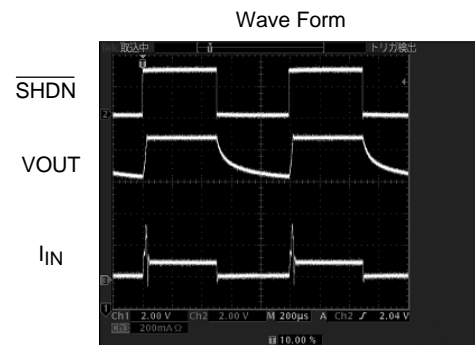
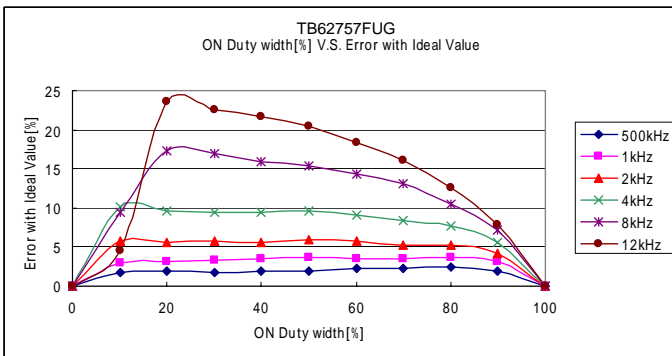

(4) $C_1 = 2.2\ \mu\text{F}$, $C_2 = 1.0\ \mu\text{F}$

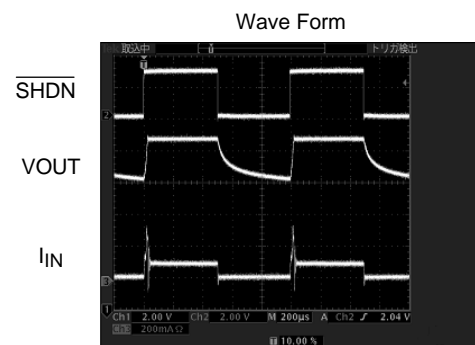
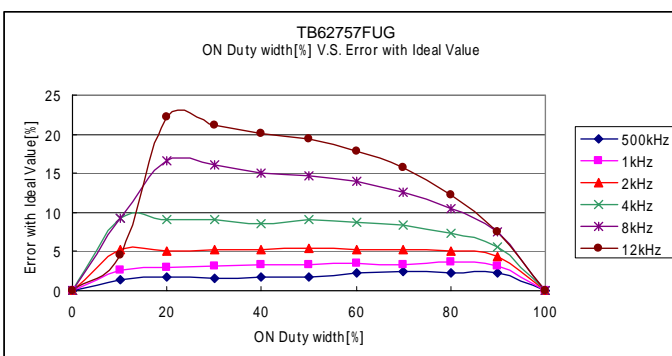

<<Recommended circuit>>

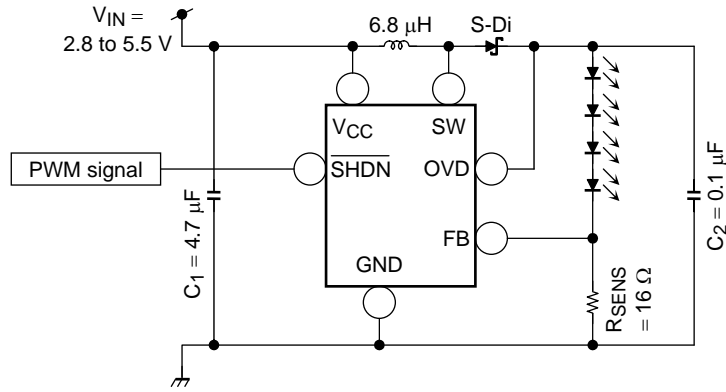

- 2) Input analog voltage to FB terminal
 IF can be adjusted with analog voltage input to FB terminal.
 This method is without repeating IC ON/OFF, and no need to consider holding rash current.

[Notice]

- LED current value goes over 100% of the current set with R_{SENS}, if the input analog voltage is between 0 V to 325 mV (typ.).

for ref.) Analog voltage = 0 to 2.2 V

About external parts value, please see recommended circuit.

| Supply Voltage [V] | Ratio with Setting Current |
|--------------------|----------------------------|
| No connect (OFF) | 100% |
| 0 | 116.0% |
| 0.2 | 106.5% |
| 0.4 | 95.4% |
| 0.6 | 84.5% |
| 0.8 | 73.6% |
| 1 | 59.9% |
| 1.2 | 48.4% |
| 1.4 | 37.4% |
| 1.6 | 26.6% |
| 1.8 | 15.9% |
| 2 | 5.8% |
| 2.2 | 0.0% |

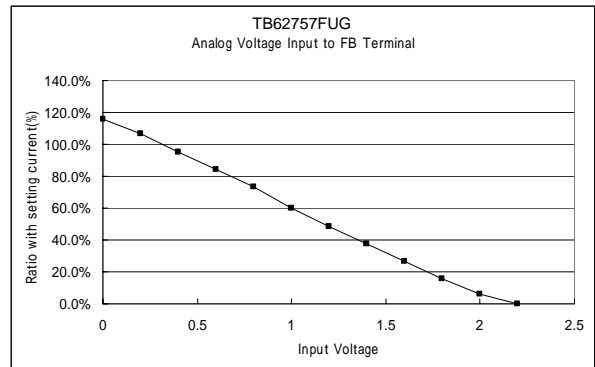

<<Recommended circuit>>

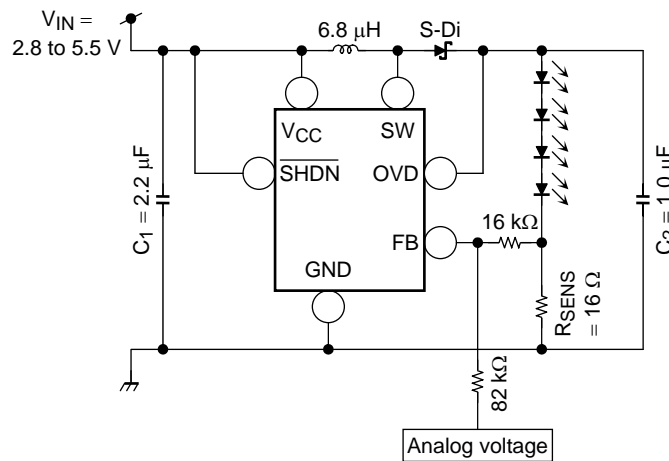

3) Input PWM signal with filtering to FB terminal

If can be adjusted with filtering PWM signal using RC filter indicated in recommended circuit, because the PWM signal can be regard as analog voltage after filtering.

This method is without repeating IC ON/OFF, and no need to consider holding rash current.

[Notice]

- LED current value goes over 100% of the current set with R_{SENS}, if the input voltage after filtering is between 0 V to 325 mV (typ.).

for ref.) Voltage during PWM Signal-ON = 2 V

About external parts value, please see recommended circuit.

| Supply Voltage [V] | Ratio with Setting Current |
|--------------------|----------------------------|
| No connect (OFF) | 100% |
| 0 | 116.1% |
| 10% | 105.3% |
| 20% | 95.1% |
| 30% | 84.8% |
| 40% | 74.6% |
| 50% | 64.0% |
| 60% | 53.8% |
| 70% | 43.7% |
| 80% | 34.0% |
| 90% | 24.2% |
| 100% | 13.3% |

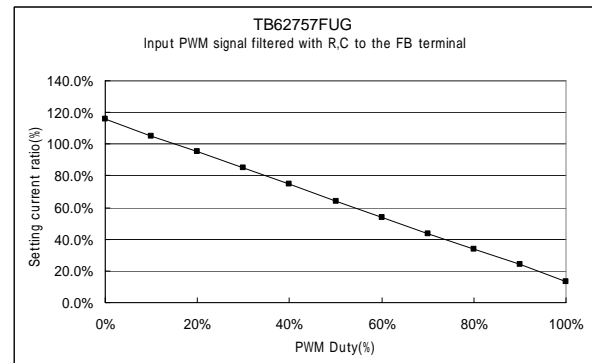

<<Recommended circuit>>

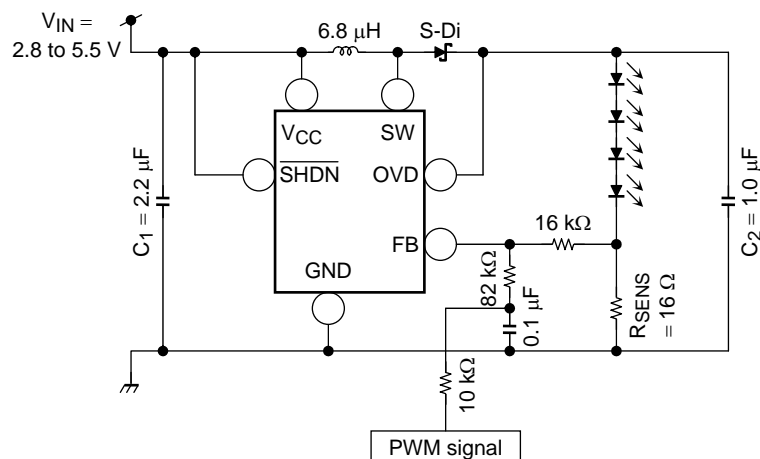

4) Input logic signal

I_F can be adjusted with Logic signal input as indicated in recommended circuit.
 The Resistor connected the ON-State Nch MOS Drain and R_{SENS} determines I_F.

Average of Setting Current I_o (mA) is next, approximately.

$$I_F = (325 \text{ [mV]} / \text{Sum of Resistor Value } [\Omega])$$

<<Recommended circuit>>

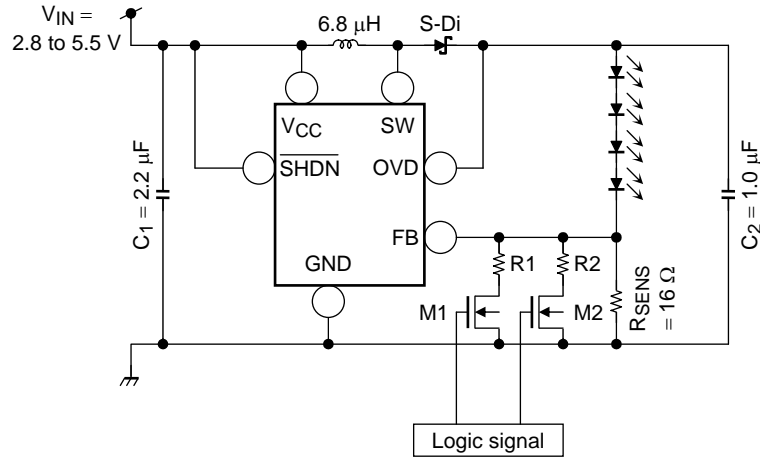

| M1 | M2 | LED Current |
|-----|-----|--|
| OFF | OFF | $\frac{325 \text{ [mV]}}{R_{SENS} [\Omega]}$ |
| ON | OFF | $325 \text{ [mV]} \times \frac{R_{SENS} [\Omega] \times R1 [\Omega]}{R_{SENS} [\Omega] + R1 [\Omega]}$ |
| OFF | ON | $325 \text{ [mV]} \times \frac{R_{SENS} [\Omega] \times R2 [\Omega]}{R_{SENS} [\Omega] + R2 [\Omega]}$ |
| ON | ON | $325 \text{ [mV]} \times \frac{R_{SENS} [\Omega] \times R1 [\Omega] \times R2 [\Omega]}{R_{SENS} [\Omega] \times R1 [\Omega] + R_{SENS} [\Omega] \times R2 [\Omega] + R1 [\Omega] \times R2 [\Omega]}$ |

Absolute Maximum Ratings (Ta = 25 °C if without notice)

| Characteristics | Symbol | Rating | Unit |
|------------------------------|-----------------------|--|------|
| Power supply voltage | V _{IN} | -0.3 to +6.0 | V |
| Input voltage | V _{SHDN} | -0.3 to + V _{IN} + 0.3 (Note 1) | V |
| Switching terminal voltage | V _o (SW) | -0.3 to 24 | V |
| Power dissipation | P _D | 0.41 (Device) | W |
| | | 0.47 (on PCB) (Note 2) | |
| Thermal resistance | R _{th} (j-a) | 300 (Device) | °C/W |
| | | 260 (on PCB) | |
| Operation temperature range | T _{opr} | -40 to +85 | °C |
| Storage temperature range | T _{stg} | -55 to +150 | °C |
| Maximum junction temperature | T _j | 150 | °C |

Note 1: However, do not exceed 6 V.

Note 2: Power dissipation must be calculated with subtraction of 3.8 mW/°C from Maximum Rating with every 1°C if T_{opr} is upper 25°C. (on PCB)

Recommended Operating Condition (Ta = -40°C to 85°C if without notice)

| Characteristics | Symbol | Test Condition | Min | Typ. | Max | Unit |
|---------------------------------|-----------------|--|-----|------|-----|------|
| Power supply voltage | V _{IN} | | 2.8 | — | 5.5 | V |
| SHDN terminal input pulse width | tpw | "H", "L" duty width | 33 | — | — | μs |
| LED current (average value) | I _{o1} | V _{IN} = 3.6 V, R _{SENS} = 16 Ω 4 white LEDs, Ta = 25°C | — | 20 | — | mA |

Electrical Characteristics (Ta = 25°C, V_{IN} = 2.8 to 5.5 V, if without notice)

| Characteristics | Symbol | Test Condition | Min | Typ. | Max | Unit |
|---------------------------------------|-----------------------|--|------|------|-----------------|------|
| Input voltage range | V _{IN} | | 2.8 | — | 5.5 | V |
| Operating consumption current | I _{IN} (On) | V _{IN} = 3.6 V, R _{SENS} = 16 Ω | — | 0.9 | 1.5 | mA |
| Quiescent consumption current | I _{IN} (Off) | V _{IN} = 3.6 V, V _{SHDN} = 0 V | — | 0.5 | 1.0 | μA |
| SHDN terminal "H" level input voltage | V _{SHDNH} | — | 1.3 | — | V _{IN} | V |
| SHDN terminal "L" level input voltage | V _{SHDNL} | — | 0 | — | 0.4 | V |
| SHDN terminal current | I _{SHDN} | V _{IN} = 3.6 V, V _{SHDN} = 3.6 V or 0 V | -10 | 0 | 10 | μA |
| Integrated MOS-Tr switching frequency | f _{OSC} | V _{IN} = 3.6 V, V _{SHDN} = 3.6 V | 0.77 | 1.1 | 1.43 | MHz |
| Sw terminal protection voltage | V _o (SW) | — | — | 25 | — | V |
| Switching terminal current | I _{oz} (SW) | — | — | 400 | — | mA |
| Switching terminal leakage current | I _{oz} (SW) | — | — | 0.5 | 1 | μA |
| FB terminal feedback voltage (VFB) | V _{FB} | V _{IN} = 3.6 V, R _{SENS} = 16 Ω, L = 6.8 μH | 308 | 325 | 342 | mV |
| FB terminal line regulation | ΔV _{FB} | V _{IN} = 3.6 V center V _{IN} = 3.0 to 5.0 V | -5 | — | 5 | % |
| OVD terminal voltage | V _{OVD} | — | 19 | 22 | 23.5 | V |
| OVD terminal leakage current | I _{OVDZ} | V _{OVD} = 16 V | — | 0.5 | 1 | μA |

1. Application Circuit Example and Measurement Data (reference data)

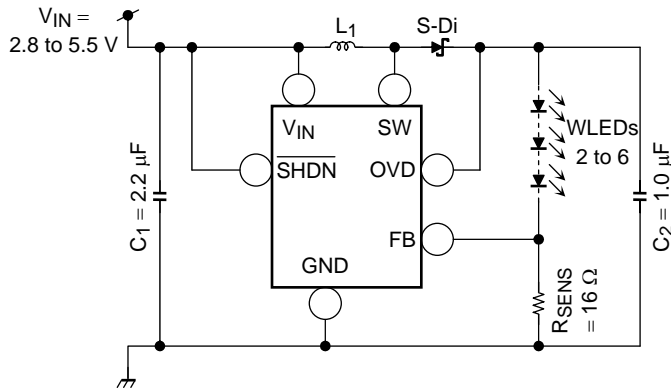

- Evaluation conditions (Ta = 25°C)
- L1 : CXLD120 series (NEO MAX CO.,Ltd.)
(Size: 2.5 mm × 3.0 mm × 1.2 mm)
- C1 : C2012JB1E225K (TDK Corp.)
- C2 : C2012JB1E105K (TDK Corp.)
- S-Di : CUS02 1 A/30 V (TOSHIBA Corp.)
- WLEDs: NSCW215T (NICHIA Corp.)

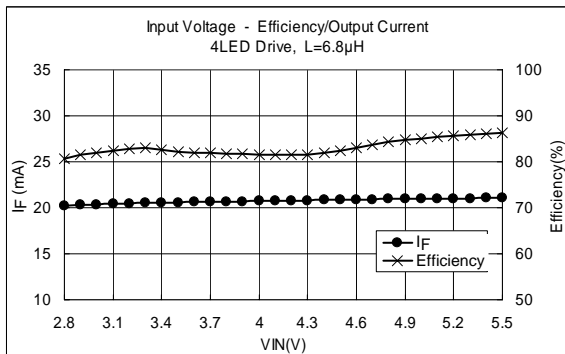
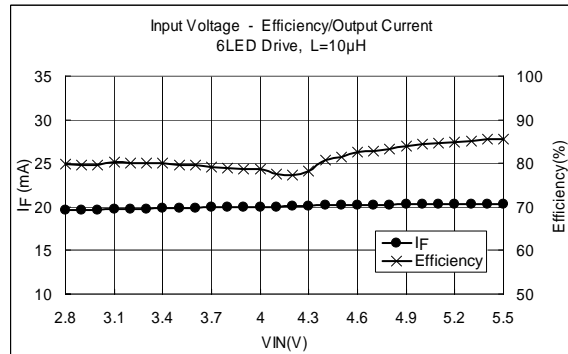
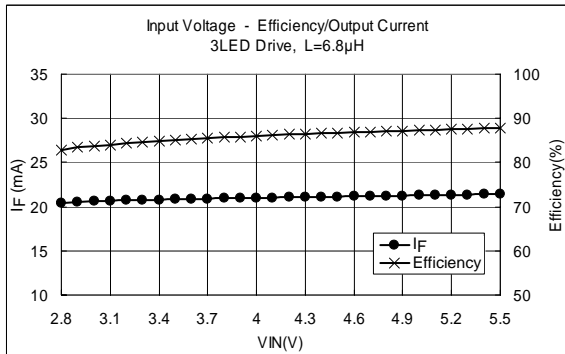
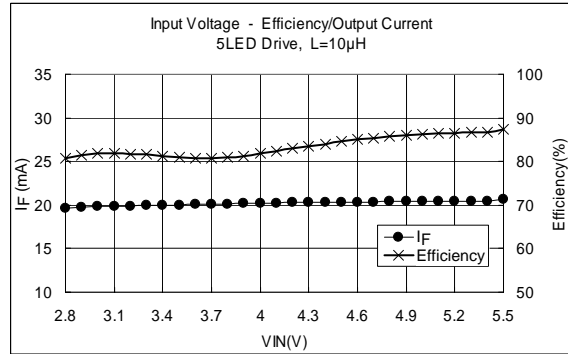
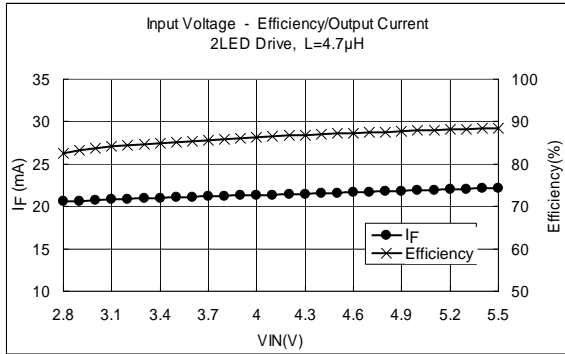

<Measurement Data>

Efficiency in the range of VIN = 2.8 to 5.5 V

| | Efficiency (%) | Average Efficiency (%) |
|--------|----------------|------------------------|
| 2 LEDs | 82.60 to 88.46 | 86.29 |
| 3 LEDs | 82.69 to 87.78 | 85.95 |
| 4 LEDs | 80.73 to 86.22 | 83.05 |
| 5 LEDs | 80.73 to 87.28 | 83.45 |
| 6 LEDs | 79.78 to 85.55 | 81.15 |

Output current in the range of VIN = 3.0 to 5.0 V (VIN = 3.6 V typ.)

| | Output Current (mA) VIN = 3.6 V | Tolerance (%) | |
|--------|------------------------------------|---------------|------|
| | | Min | Max |
| 2 LEDs | 21.13 | -3.50 | 1.77 |
| 3 LEDs | 20.60 | -1.95 | 1.38 |
| 4 LEDs | 20.87 | -1.75 | 1.11 |
| 5 LEDs | 20.06 | -1.81 | 1.15 |
| 6 LEDs | 19.90 | -1.95 | 1.28 |

* VOUT voltage in driving 5 or 6 LEDs must be lower than OVD detection level. (VOUT < 19 V)

Note: These application examples are provided for reference only. Thorough evaluation and testing should be implemented when designing your application's mass production design.

2. Application Circuit Example and Measurement Data (reference data)

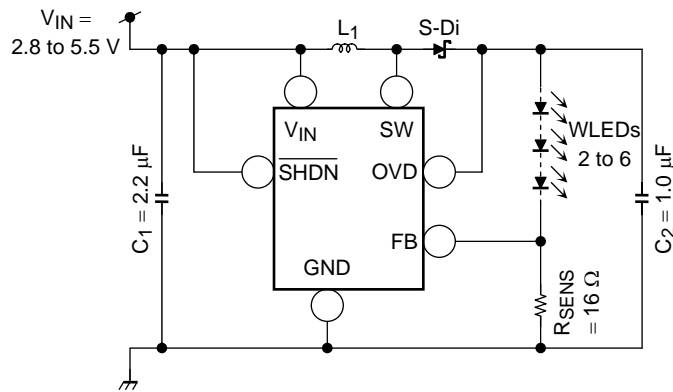

- Evaluation conditions (Ta = 25°C)
- L1 : 1001AS series (TOKO, INC)
(Size: 3.6 mm × 3.6 mm × 1.2 mm)
- C1 : C2012JB1E225K (TDK Corp.)
- C2 : C2012JB1E105K (TDK Corp.)
- S-Di : CUS02 1 A/30 V (TOSHIBA Corp.)
- WLEDs: NSCW215T (NICHIA Corp.)

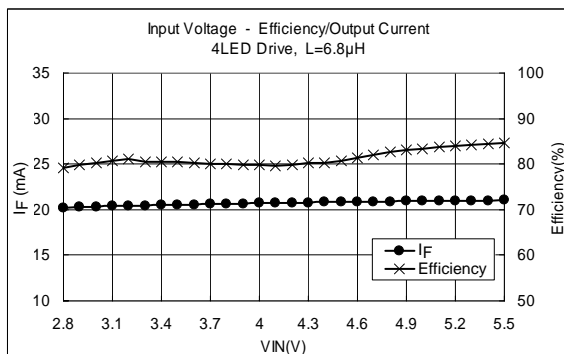
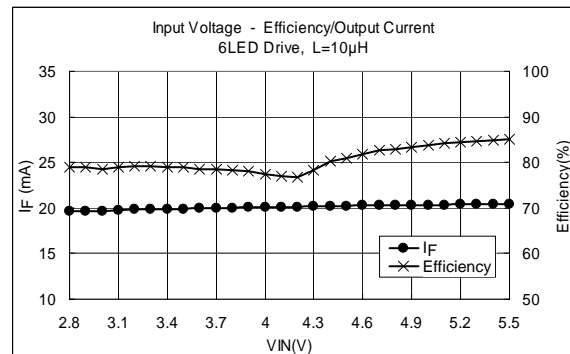
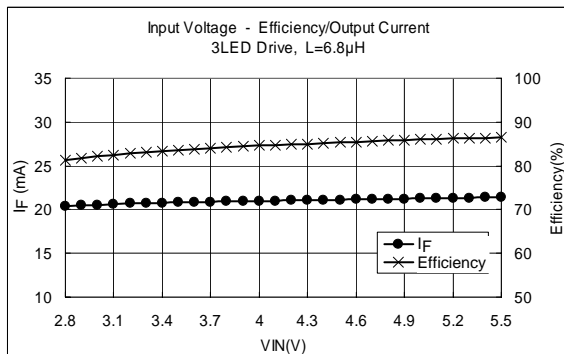
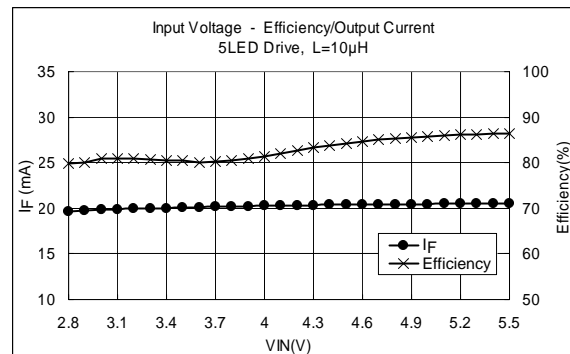
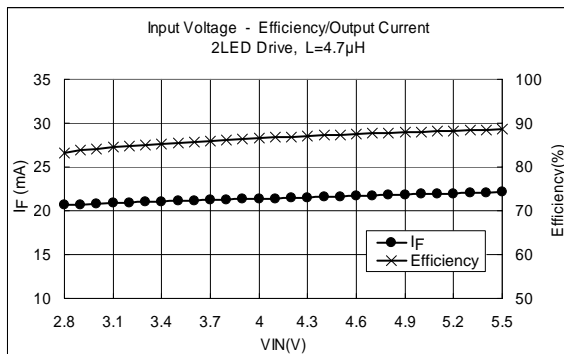

<Measurement Data>

Efficiency in the range of VIN = 2.8 to 5.5 V

| | Efficiency (%) | Average Efficiency (%) |
|--------|----------------|------------------------|
| 2 LEDs | 83.10 to 88.60 | 86.55 |
| 3 LEDs | 81.32 to 86.47 | 84.54 |
| 4 LEDs | 79.15 to 84.63 | 81.30 |
| 5 LEDs | 79.72 to 86.39 | 82.87 |
| 6 LEDs | 78.91 to 85.10 | 80.47 |

Output current in the range of VIN = 3.0 to 5.0 V (VIN = 3.6 V typ.)

| | Output Current (mA) VIN = 3.6 V | Tolerance (%) | |
|--------|------------------------------------|---------------|------|
| | | Min | Max |
| 2 LEDs | 21.17 | -3.32 | 1.73 |
| 3 LEDs | 20.85 | -1.95 | 1.38 |
| 4 LEDs | 20.56 | -1.79 | 1.15 |
| 5 LEDs | 20.10 | -1.82 | 1.22 |
| 6 LEDs | 19.95 | -1.94 | 1.26 |

* VOUT voltage in driving 5 or 6 LEDs must be lower than OVD detection level. (VOUT < 19 V)

Note: These application examples are provided for reference only. Thorough evaluation and testing should be implemented when designing your application's mass production design.

3. Application Circuit Example and Measurement Data (reference data)

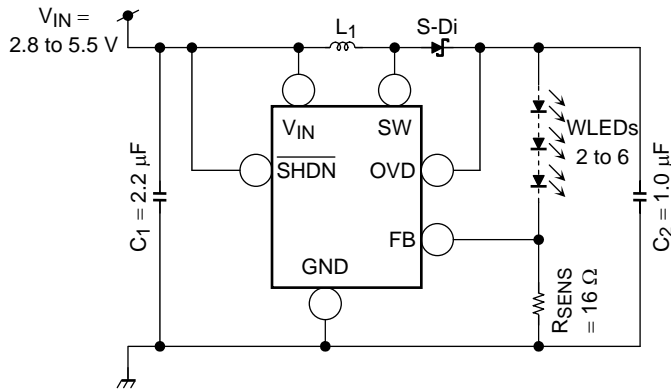

- Evaluation conditions (Ta = 25°C)
- L1 : LQH2M series (Murata Manufacturing Co.,Ltd.) (Size: 2.0 mm × 1.6 mm × 0.95 mm)
- C1 : C2012JB1E105K (TDK Corp.)
- C2 : C2012JB1E105K (TDK Corp.)
- S-Di : CUS02 1 A/30 V (TOSHIBA Corp.)
- WLEDs: NSCW215T (NICHIA Corp.)

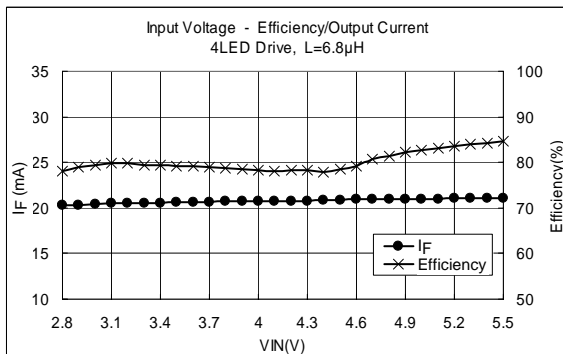
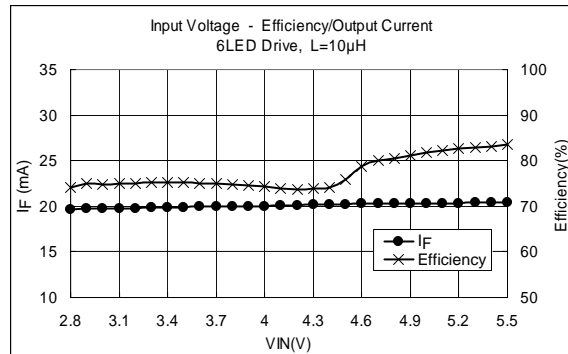
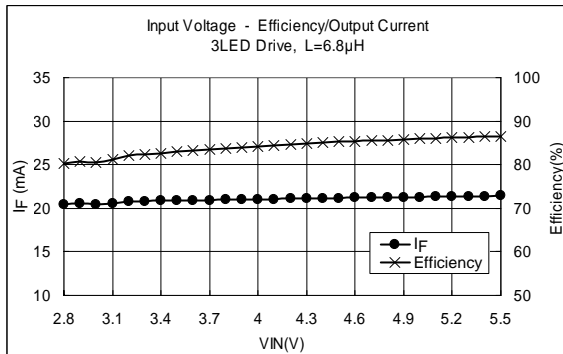
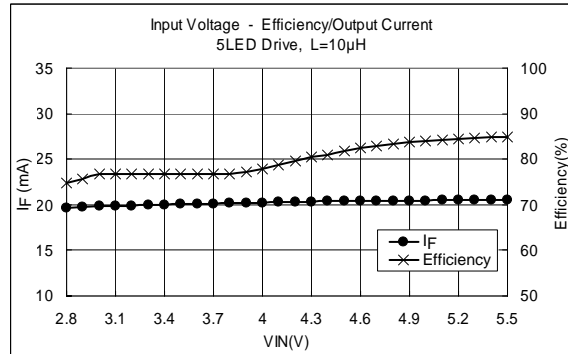
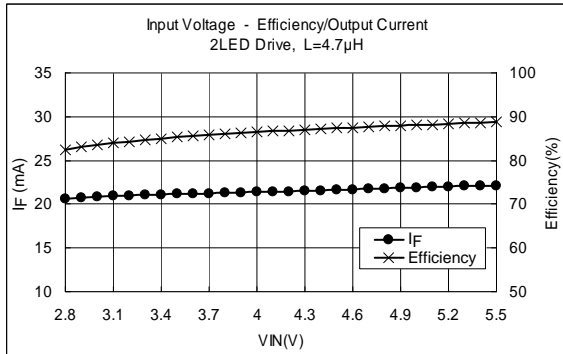

<Measurement Data>

Efficiency in the range of VIN = 2.8 to 5.5 V

| | Efficiency (%) | Average Efficiency (%) |
|--------|----------------|------------------------|
| 2 LEDs | 82.37 to 88.70 | 86.38 |
| 3 LEDs | 80.19 to 86.55 | 84.12 |
| 4 LEDs | 78.11 to 84.54 | 80.16 |
| 5 LEDs | 74.79 to 84.94 | 79.94 |
| 6 LEDs | 74.14 to 83.47 | 77.17 |

Output current in the range of VIN = 3.0 to 5.0 V (VIN = 3.6 V typ.)

| | Output Current (mA) VIN = 3.6 V | Tolerance (%) | |
|--------|------------------------------------|---------------|------|
| | | Min | Max |
| 2 LEDs | 21.19 | -3.26 | 1.69 |
| 3 LEDs | 20.90 | -1.87 | 2.17 |
| 4 LEDs | 20.63 | -1.78 | 1.01 |
| 5 LEDs | 20.09 | -1.88 | 1.25 |
| 6 LEDs | 19.93 | -1.99 | 1.07 |

* VOUT voltage in driving 5 or 6 LEDs must be lower than OVD detection level. (VOUT < 19 V)

Note: These application examples are provided for reference only. Thorough evaluation and testing should be implemented when designing your application's mass production design.

4. Application Circuit Example and Measurement Data (reference data)

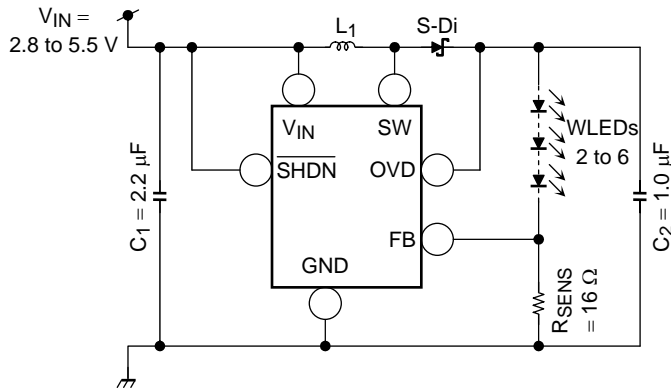

- Evaluation conditions (Ta = 25°C)
 - L1 : VLF3010A series (TDK Corp.)
(Size: 3.0 mm × 3.0 mm × 1.0 mm)
 - C1 : C2012JB1E225K (TDK Corp.)
 - C2 : C2012JB1E105K (TDK Corp.)
 - S-Di : CUS02 1 A/30 V (TOSHIBA Corp.)
 - WLEDs: NSCW215T (NICHIA Corp.)

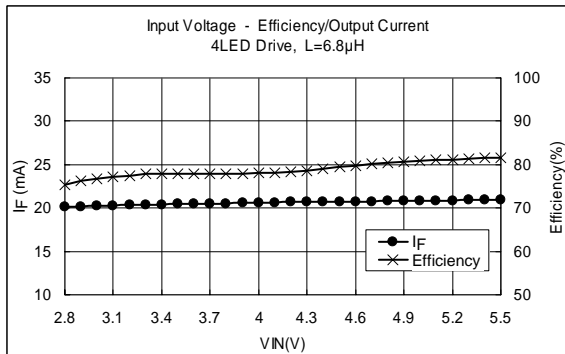
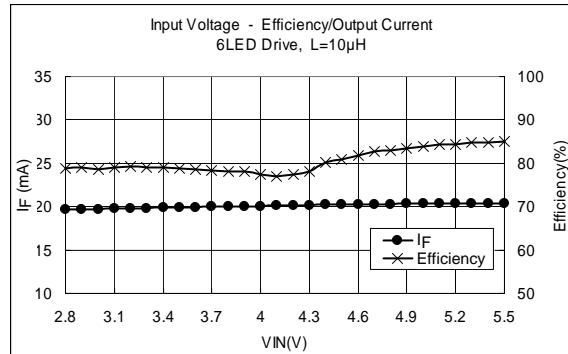
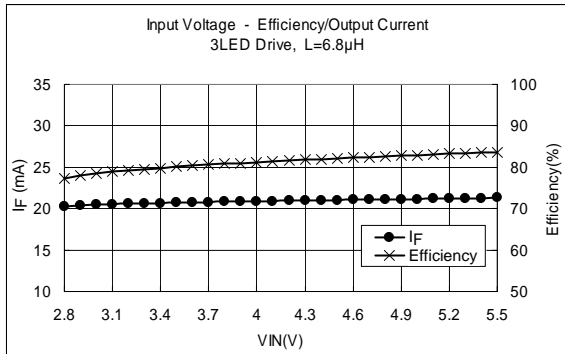
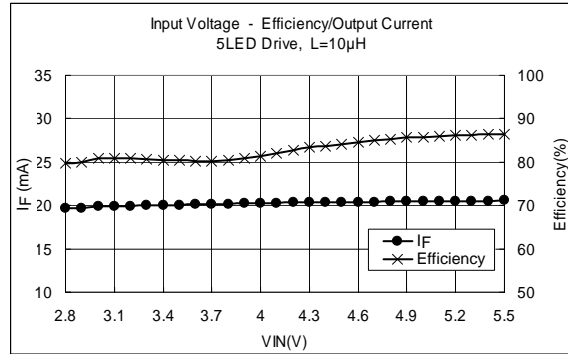
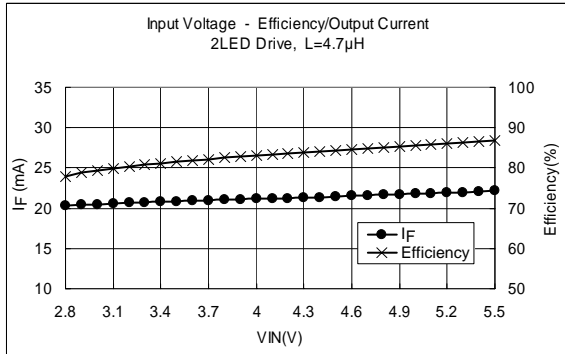

<Measurement Data>

Efficiency in the range of VIN = 2.8 to 5.5 V

| | Efficiency (%) | Average Efficiency (%) |
|--------|----------------|------------------------|
| 2 LEDs | 79.85 to 86.97 | 84.02 |
| 3 LEDs | 80.19 to 85.32 | 83.39 |
| 4 LEDs | 78.77 to 83.60 | 80.69 |
| 5 LEDs | 79.72 to 86.39 | 82.87 |
| 6 LEDs | 78.91 to 85.10 | 80.49 |

Output current in the range of VIN = 3.0 to 5.0 V (VIN = 3.6 V typ.)

| | Output Current (mA) VIN = 3.6 V | Tolerance (%) | |
|--------|------------------------------------|---------------|------|
| | | Min | Max |
| 2 LEDs | 21.19 | -3.08 | 1.67 |
| 3 LEDs | 20.89 | -1.86 | 1.33 |
| 4 LEDs | 20.64 | -1.68 | 1.11 |
| 5 LEDs | 20.10 | -1.82 | 1.22 |
| 6 LEDs | 19.95 | -1.94 | 1.26 |

* VOUT voltage in driving 5 or 6 LEDs must be lower than OVD detection level. (VOUT < 19 V)

Note: These application examples are provided for reference only. Thorough evaluation and testing should be implemented when designing your application's mass production design.

5. Application Circuit Example and Measurement Data (reference data)

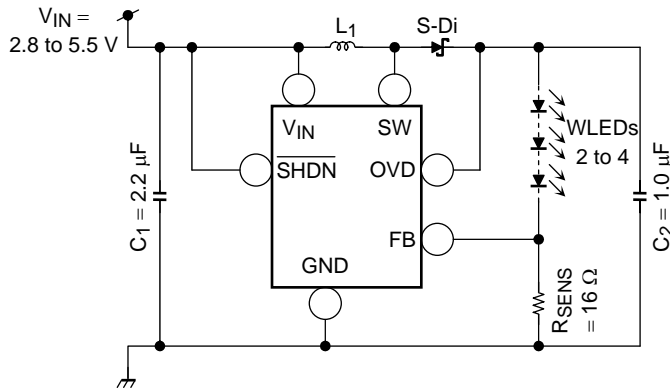

- Evaluation conditions (Ta = 25°C)
- L1 : 32R51 (KOA Corp.)
(Size: 3.2 mm × 2.5 mm × 0.6 mm)
- C1 : C2012JB1E225K (TDK Corp.)
- C2 : C2012JB1E105K (TDK Corp.)
- S-Di : CUS02 1 A/30 V (TOSHIBA Corp.)
- WLEDs: NSCW215T (NICHIA Corp.)

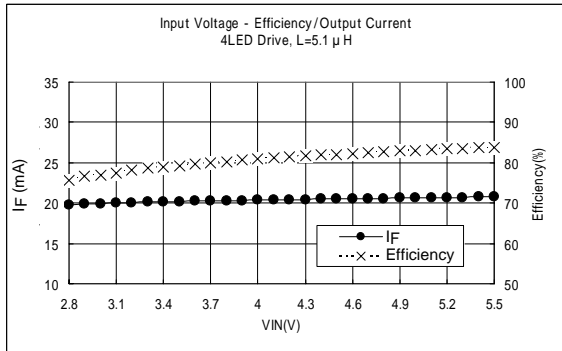
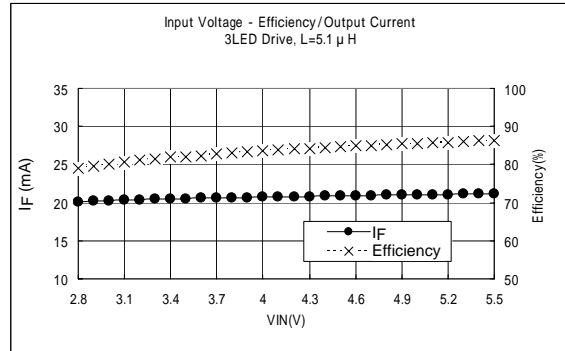
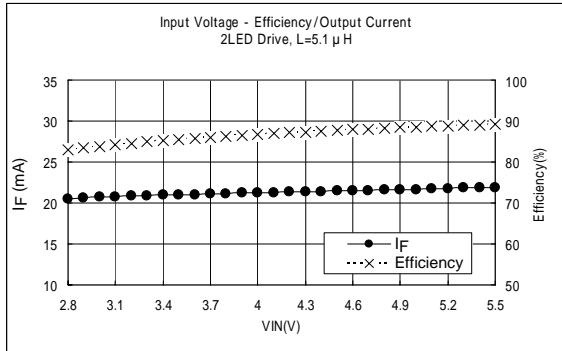

<Measurement Data>

Efficiency in the range of VIN = 2.8 to 5.5 V

| | Efficiency (%) | Average Efficiency (%) |
|--------|----------------|------------------------|
| 2 LEDs | 83.08 to 89.23 | 86.73 |
| 3 LEDs | 79.02 to 86.30 | 83.52 |
| 4 LEDs | 75.75 to 83.83 | 80.78 |

Output current in the range of VIN = 3.0 to 5.0 V (VIN = 3.6 V typ.)

| | Output Current (mA) VIN = 3.6 V | Tolerance (%) | |
|--------|------------------------------------|---------------|------|
| | | Min | Max |
| 2 LEDs | 21.06 | -2.46 | 4.02 |
| 3 LEDs | 20.57 | -2.39 | 2.94 |
| 4 LEDs | 20.22 | -2.28 | 2.65 |

Note: These application examples are provided for reference only. Thorough evaluation and testing should be implemented when designing your application's mass production design.

Package Dimensions

Weight: TBDg (typ.)

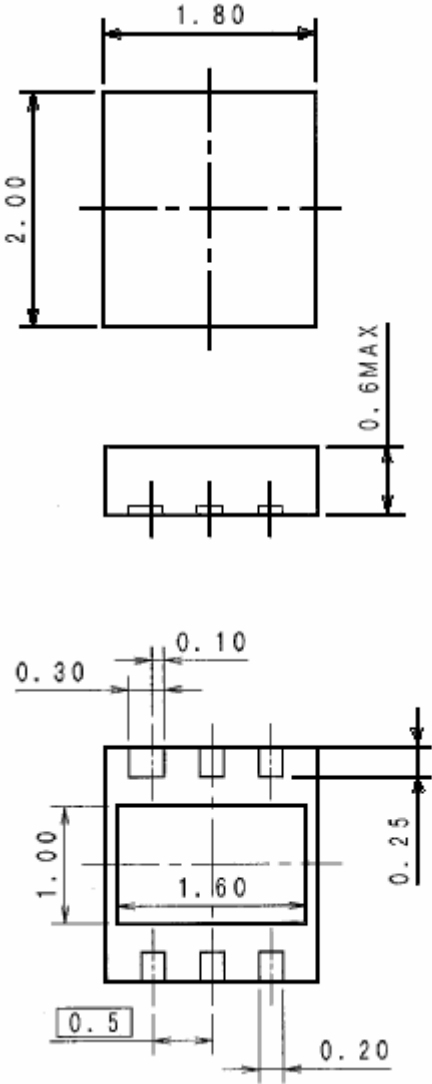

Notes on Contents**1. Block Diagrams**

Some of the functional blocks, circuits, or constants in the block diagram may be omitted or simplified for explanatory purposes.

2. Equivalent Circuits

The equivalent circuit diagrams may be simplified or some parts of them may be omitted for explanatory purposes.

3. Timing Charts

Timing charts may be simplified for explanatory purposes.

4. Application Circuits

The application circuits shown in this document are provided for reference purposes only. Thorough evaluation is required, especially at the mass production design stage.

Toshiba does not grant any license to any industrial property rights by providing these examples of application circuits.

5. Test Circuits

Components in the test circuits are used only to obtain and confirm the device characteristics. These components and circuits are not guaranteed to prevent malfunction or failure from occurring in the application equipment.

IC Usage Considerations

Notes on handling of ICs

- [1] The absolute maximum ratings of a semiconductor device are a set of ratings that must not be exceeded, even for a moment. Do not exceed any of these ratings.
Exceeding the rating(s) may cause the device breakdown, damage or deterioration, and may result injury by explosion or combustion.
- [2] Use an appropriate power supply fuse to ensure that a large current does not continuously flow in case of over current and/or IC failure. The IC will fully break down when used under conditions that exceed its absolute maximum ratings, when the wiring is routed improperly or when an abnormal pulse noise occurs from the wiring or load, causing a large current to continuously flow and the breakdown can lead smoke or ignition. To minimize the effects of the flow of a large current in case of breakdown, appropriate settings, such as fuse capacity, fusing time and insertion circuit location, are required.
- [3] If your design includes an inductive load such as a motor coil, incorporate a protection circuit into the design to prevent device malfunction or breakdown caused by the current resulting from the inrush current at power ON or the negative current resulting from the back electromotive force at power OFF. IC breakdown may cause injury, smoke or ignition.
Use a stable power supply with ICs with built-in protection functions. If the power supply is unstable, the protection function may not operate, causing IC breakdown. IC breakdown may cause injury, smoke or ignition.
- [4] Do not insert devices in the wrong orientation or incorrectly.
Make sure that the positive and negative terminals of power supplies are connected properly.
Otherwise, the current or power consumption may exceed the absolute maximum rating, and exceeding the rating(s) may cause the device breakdown, damage or deterioration, and may result injury by explosion or combustion.
In addition, do not use any device that is applied the current with inserting in the wrong orientation or incorrectly even just one time.
- [5] Carefully select external components (such as inputs and negative feedback capacitors) and load components (such as speakers), for example, power amp and regulator.
If there is a large amount of leakage current such as input or negative feedback condenser, the IC output DC voltage will increase. If this output voltage is connected to a speaker with low input withstand voltage, overcurrent or IC failure can cause smoke or ignition. (The over current can cause smoke or ignition from the IC itself.) In particular, please pay attention when using a Bridge Tied Load (BTL) connection type IC that inputs output DC voltage to a speaker directly.

About solderability, following conditions were confirmed

- Solderability

- (1) Use of Sn-37Pb solder Bath

- solder bath temperature = 230°C
 - dipping time = 5 seconds
 - the number of times = once
 - use of R-type flux

- (2) Use of Sn-3.0Ag-0.5Cu solder Bath

- solder bath temperature = 245°C
 - dipping time = 5 seconds
 - the number of times = once
 - use of R-type flux

RESTRICTIONS ON PRODUCT USE

030619EBA

- The information contained herein is subject to change without notice.
- The information contained herein is presented only as a guide for the applications of our products. No responsibility is assumed by TOSHIBA for any infringements of patents or other rights of the third parties which may result from its use. No license is granted by implication or otherwise under any patent or patent rights of TOSHIBA or others.
- TOSHIBA is continually working to improve the quality and reliability of its products. Nevertheless, semiconductor devices in general can malfunction or fail due to their inherent electrical sensitivity and vulnerability to physical stress. It is the responsibility of the buyer, when utilizing TOSHIBA products, to comply with the standards of safety in making a safe design for the entire system, and to avoid situations in which a malfunction or failure of such TOSHIBA products could cause loss of human life, bodily injury or damage to property.
In developing your designs, please ensure that TOSHIBA products are used within specified operating ranges as set forth in the most recent TOSHIBA products specifications. Also, please keep in mind the precautions and conditions set forth in the "Handling Guide for Semiconductor Devices," or "TOSHIBA Semiconductor Reliability Handbook" etc..
- The TOSHIBA products listed in this document are intended for usage in general electronics applications (computer, personal equipment, office equipment, measuring equipment, industrial robotics, domestic appliances, etc.). These TOSHIBA products are neither intended nor warranted for usage in equipment that requires extraordinarily high quality and/or reliability or a malfunction or failure of which may cause loss of human life or bodily injury ("Unintended Usage"). Unintended Usage include atomic energy control instruments, airplane or spaceship instruments, transportation instruments, traffic signal instruments, combustion control instruments, medical instruments, all types of safety devices, etc.. Unintended Usage of TOSHIBA products listed in this document shall be made at the customer's own risk.
- The products described in this document are subject to the foreign exchange and foreign trade laws.
- TOSHIBA products should not be embedded to the downstream products which are prohibited to be produced and sold, under any law and regulations.